

Window Treatments

A variety of treatments are used to enhance the winter and summer thermal performance of windows. Window treatments for cold weather are generally different than window treatments for hot weather. Cold weather window treatments reduce the window's U-factor and include storm windows and window insulation. Hot weather improvements reduce solar heat gain and include sun screens, awnings, window films, interior shades and blinds, and shutters.

See "Shading Windows" on page 205 for an extensive discussion of window shading.

Exterior Storm Windows

Exterior storm windows are the primary window's first defense against the weather. They are important to preserving old buildings and their windows.

If the exterior storm window is too airtight, the storm can trap moist air from indoors and contribute to fogging and icing of the exterior window. The fogging or icing can be reduced or eliminated by tightening the primary window.

Exterior storm windows appear very similar to one another making it difficult to categorize these windows by quality. The following is a list of features which are important in selecting an exterior metal storm window:

- ◆ Frame should be sturdy—sashes should not have a tendency to fall apart or deform during installation.
- ◆ The gasket that seals the glass should surround the edge of the glass and not just wedge the glass into place on the sides of the sash.
- ◆ Interlock at the meeting rail should be tightly sealed.
- ◆ The frame should have weep holes on the bottom to let water out of the window assembly.

- ◆ The window should fit well; installation work should be good quality.
- ◆ Sashes should be removable from indoors.
- ◆ Plastic parts should be confined to those parts that need to slide against the aluminum. Other parts should be metal.

Exterior storm windows with plastic frames and sashes are available, but not yet popular. Plastic must have the ability to withstand the extremes of temperature and ultraviolet sunlight.

Wood-framed storm/screen combination units are increasingly popular with period home enthusiasts. Well-designed and constructed wooden storm windows still require occasional painting, but have the advantage of blending well with the architecture.

Interior Storm Windows

Interior storm windows are designed with an effective perimeter air seal to prevent the warm, moist, indoor air from depositing condensation on the cool primary window during the winter.

Many interior storm windows have flexible or rigid plastic glazing that gives them a slightly higher R-value than glass interior storms.

It's important to look closely at the frames, sashes, and seals of the interior storm window assembly to estimate how long the window will last. Be skeptical about magnetic tape and other components that depend on adhesives as their sole means of attachment to the existing window frame.

Installing an inexpensive metal primary window at the interior side of the exterior primary window is a popular treatment for creating double glazing in hotels and apartment buildings. Mobile homes also use the strategy of having a secondary operable window inside the exterior primary window.

Interior Storm Windows

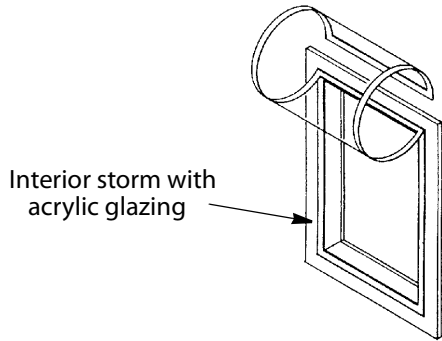

Interior storm with acrylic glazing

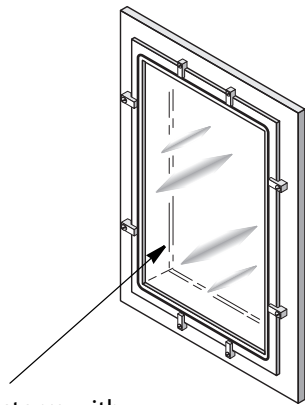

Interior storm with flexible PVC glazing

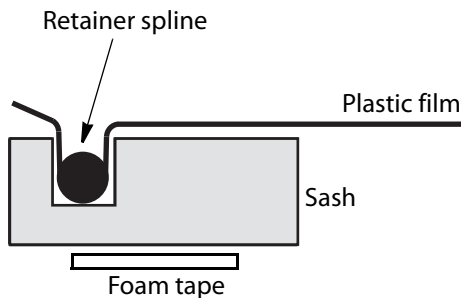

Interior storms must be air barriers to keep warm, moist, indoor air from depositing condensation on the primary window.

Double Window System

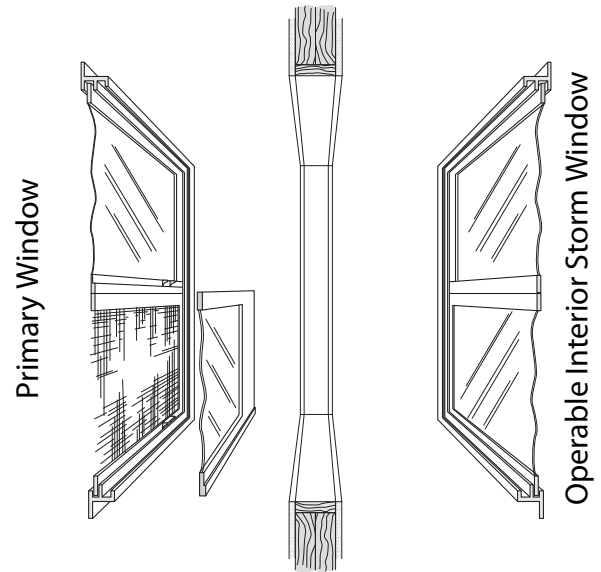

Employing a double window system is an alternative to window replacement, for single-pane primary windows.

Insulating Shades and Draperies

Insulating shades and draperies are very effective for insulating windows and improving comfort indoors. They are expensive and require many years to return the investment, but they cost considerably less per square foot than a new window. Insulation for the building shell and storm windows should take priority over insulating window coverings.

If your home is well-insulated and the windows present a comfort problem in cold weather, window insulation will improve your comfort and save energy. The shades, draperies, or shutters are more effective if they are airtight, because they create a dead air space between themselves and the glass, and because the airtight seal prevents warm, moist indoor air from depositing condensation on the glass.