



## New Energy-Efficient Combustion Furnaces and Boilers

The most important advances made by newer energy-efficient heaters over older conventional models are control of combustion air and elimination of dilution air. Draft inducer fans or high-pressure, forced-draft fans ration combustion air to the heat exchanger. This forces combustion by-products through tighter spaces, where more heat is removed compared to older heaters. Dilution air — which exhausts heated air from the home — is eliminated because a small blower controls the chimney draft instead of the dilution device.

High-efficiency furnaces and boilers have AFUEs of 80% to 97%, compared to conventional furnaces and boilers with AFUEs of 65% to 78%. The high-efficiency furnaces and boilers contain a number of important improvements over older models:

- ◆ Electronic ignition (no pilot light).
- ◆ Heat exchangers that restrict combustion gases, squeezing more heat out of them.
- ◆ Fans to move the combustion air through the smaller flues.

- ◆ Water condensed from flue gases in a corrosion-resistant heat exchanger for extra efficiency.
- ◆ Compact size and lighter weight, reducing off-cycle losses.

When replacing a furnace or boiler, do the following:

- ◆ Insist on proper installation.
- ◆ Be sure that deficiencies in ducts, piping, chimney, gas service, and electrical supply be corrected as part of the installation.
- ◆ Confirm that parts and service will be available in the future.
- ◆ Compare the competing warranties of the furnaces or boilers.
- ◆ Establish a maintenance schedule for the new furnace or boiler.

### Characteristics of Gas Furnaces

AFUE	SSE	Operating characteristics
60+	70+	Category I chimney, draft diverter, no draft fan, standing pilot, non-condensing, indoor combustion and dilution air.
78+	80+	Category I chimney, no draft diverter, draft fan, electronic ignition, indoor combustion air, no dilution air.
90+	90+	Category IV chimney, no draft diverter, draft fan, low-temperature plastic venting, positive draft, electronic ignition, condensing heat exchanger, outdoor combustion air is strongly recommended.

Evolution of Gas Furnaces

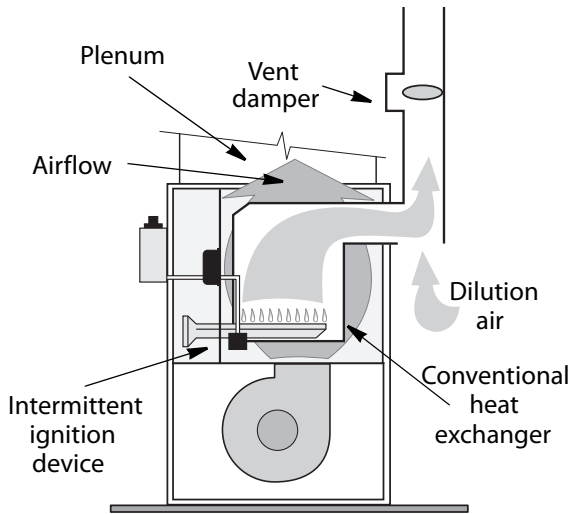

Improved Conventional Furnace

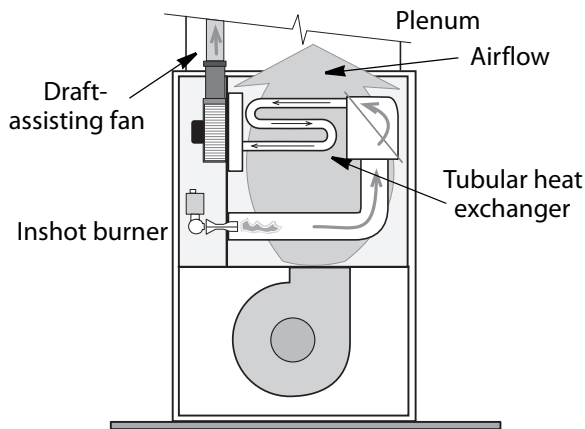

80%+ Draft-Assisted Furnace

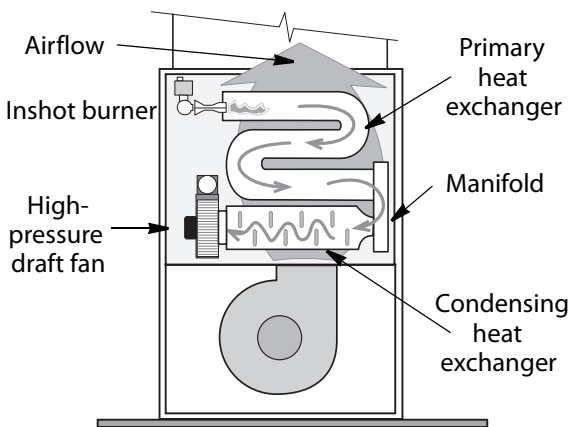

Condensing Furnace

Modern Wall-Hung Boiler

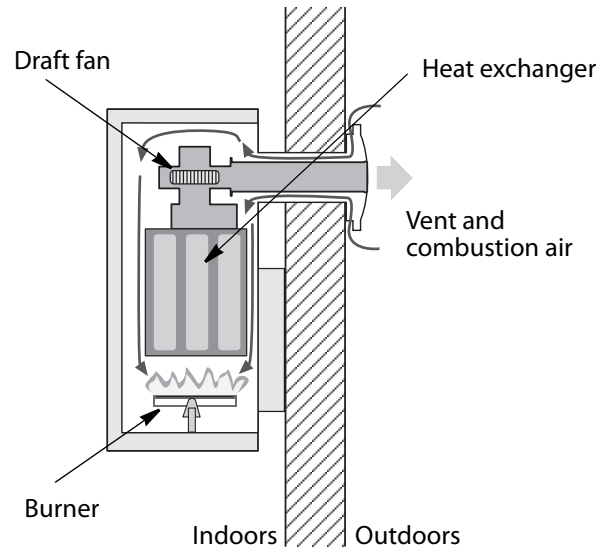

Wall hung boilers are very popular in Europe and becoming more popular in the U.S. The best European models, now available in North America, provide precise control of both gas flow and combustion air.

Energy-efficient Oil Furnaces and Boilers

Energy-efficient oil furnaces and boilers can reach AFUEs of almost 90% without condensing water out of the flue gases. They achieve this by employing a flame retention head oil burner (FRHOB), which gives nearly perfect combustion with very low excess air.

The delayed-action solenoid valve on many new units greatly reduces sooting at start-up, and oil dribble from the nozzle on shutdown. The solenoid valve allows the oil and air pressure to build before releasing the stream of oil from the nozzle.

Solid-state igniters have replaced transformers in newer oil burners, and some of these igniters are interruptible — they turn off after initial ignition — saving considerable electrical energy. Many newer oil burners have permanent split-capacitor motors, which provide electrical savings over conventional motors.

Some new oil heaters eliminate the barometric draft control, and its inefficient dilution air, using a horizontal vent with a power venter or a high pressure burner that doesn't need the barometric control. Eliminating dilution air saves up to 10% over a furnace with just a flame retention head burner.

Condensing oil heaters are available, but their market share is very small. Oil combustion doesn't produce as much water vapor to condense as natural gas. Also, the condensate is very acidic and may corrode parts of the flue and heat exchanger.

### Energy-efficient Gas Systems

There are two modern choices of furnaces and boilers: mid-efficiency and high-efficiency condensing. Both of these technologies have electronic ignition, no draft diverter, and improved heat-exchanger design.

Mid-efficiency heaters have a draft-assisting fan in the flue downstream of the heat exchanger. The draft fan forces exhaust gases out at a controlled rate, pulling combustion air into the heat exchanger at the same time. The draft fan reduces excess air, compared to older furnaces with draft diverters. Mid-efficiency furnaces and boilers also eliminate dilution air — a large energy-waster in older furnaces and boilers. The savings for a mid-efficiency furnace compared to a conventional unit, is 10% to 20%, assuming an AFUE of around 80%. Mid-efficiency heaters are vented vertically into existing chimneys or horizontally, through an exterior wall.

Natural gas combustion produces large amounts of water vapor. About 12% of the total heat in the gas is tied up in that water vapor's latent heat. This accounts for the high-efficiency heaters' dramatic

increase of AFUE from 82% to 95% and savings over an older gas furnace of 20% to 30%. The water vapor condenses in a stainless steel portion of the heat exchanger and flows to a drain. The combustion gases exit at 100°F through corrosion-resistant plastic pipe, horizontally or vertically.

Mid-efficiency furnaces and boilers have had problems with condensation in their chimneys and heat exchangers. Condensing furnaces have the advantage of being designed to use the latent heat from condensing flue gases and to resist corrosion.

Both mid-efficiency and high-efficiency furnaces are available in two-stage models. The two-stage heating is accomplished by a two-stage gas valve, a two-speed draft fan, and a two-speed blower. The first stage is about half the heating capacity of the second stage. The two-stage strategy reduces cycling and improves comfort. However, two-stage furnaces are probably no more efficient than single-stage ones. The imprecise control of combustion air continues to prevent the heating industry from supplying more efficient and clean-burning furnaces.

### Integrated Heating Systems

A new generation of packaged HVAC units may provide a solution to combustion air and excessive chimney losses. Powered by a small boiler, these units provide space heating, water heating, ventilation, and air conditioning if necessary. Using a single efficient boiler with a single vent for both space heating and water heating increases space-heating efficiency and water-heating efficiency over having separate vents for each. Hopefully, the new boiler features the kind of precise combustion-air control and clean combustion of the best German boilers of today.

### Integrated Space and Water Heating

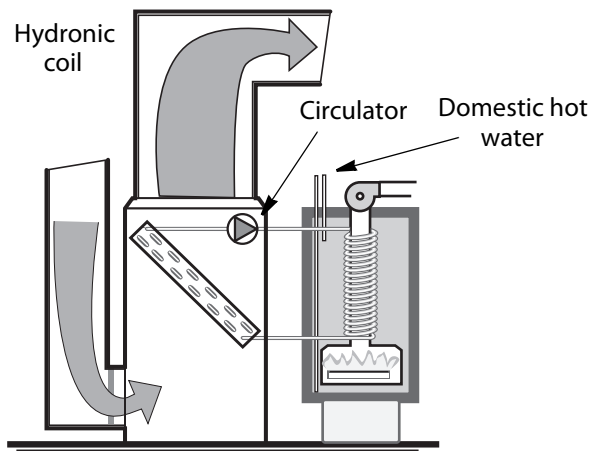

Several companies already make integrated space-and-water heating systems with air handlers.

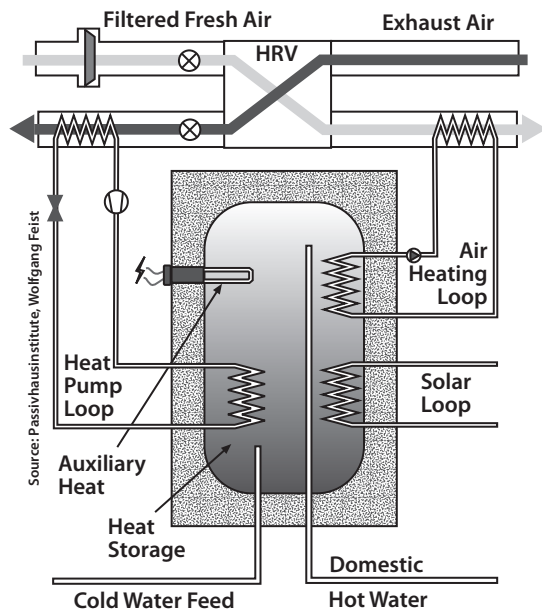

German and Austrian compact HVAC units combine heating, water heating, and heat-recovery ventilation.

The Germans and Austrians have designed compact heating and water-heating units for installation into energy-efficient homes. These units feature a variety of possible heating inputs including gas, heat pump, and solar. Hot-water storage

is often incorporated into the same cabinet as the heating and ventilating equipment. The packaged unit also often contains a heat-recovery ventilator.

## Combustion Room Heaters

Combustion room heaters are very common in older residential buildings and buildings in mild heating climates. Wood stoves saw a resurgence in the 1980s, but declined through the 1990s. Pellet stoves and gas fireplaces replaced wood stoves as room heaters in many homes. Then wood stoves surged again after oil prices rose after the turn of the 21st century.

### Gas Room Heaters

Gas room heaters have steady-state efficiencies of between 60% and 75%. There are four common types of gas room heaters.

1. Freestanding room heater.
2. Floor furnace.
3. Recessed wall furnace.
4. Direct-vent wall furnace.

The first three models are older designs that may have obsolete flame-safety controls. The oldest existing units may have no flame-safety control, but only manual control of the pilot valve and the main gas valve. Units with obsolete or absent flame-safety controls should be replaced or retrofitted with modern combination gas valves equipped with flame-safety control.

The first three types of heaters are open-combustion — their combustion chamber and chimney are open to the room. The fourth, direct-vent wall furnaces are sealed-combustion heaters with horizontal vents. Older models use atmospheric draft to draw combustion air and exhaust combustion gases. Newer models have a draft fan.

Room heaters with draft or combustion problems are particularly dangerous because they are located within the living space. Floor furnaces

often have backdrafting problems due to the long horizontal run of vent connector they require because of their typical location in the center of a room. Heating professionals should test room heaters for CO and draft to ensure that they don't pose an immediate danger.

Most gas room heaters have integral thermostats with numbered dials. The numbers are for reference and don't relate to temperature. Some floor furnaces and wall furnaces have wall-mounted thermostats that give better room comfort than integral thermostats.

### New Efficient Gas Room Heaters

New energy-efficient gas room heaters look very similar to the older models. However, they use a variety of efficiency improvements to achieve steady-state efficiencies between 78% and 82%. These improvements include:

- ◆ Lighter metal heat exchangers.
- ◆ Blowers to circulate room air.
- ◆ More restrictive flow of combustion gases, leading to less excess air.
- ◆ Intermittent pilot lights.

#### Energy-Efficient Gas Space Heater

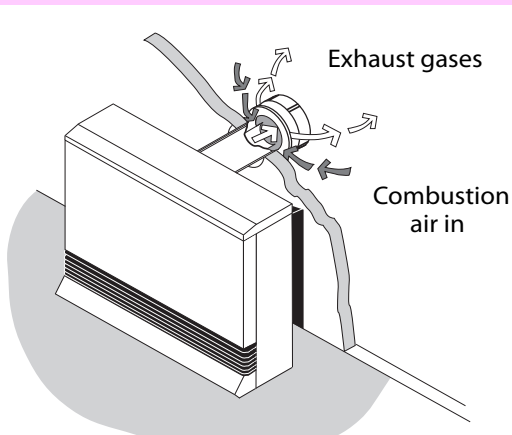

New sealed-combustion gas space heaters are safer and more efficient than older gas space heaters.

The safest and most efficient space heaters also have a draft fan and are sealed combustion. These include the console model shown in the illustration and a baseboard model resembling an electric baseboard heater.

Condensing room heaters aren't yet commercially available.

### Unvented Gas Room Heaters

Unvented room heaters can deplete oxygen and produce unsafe quantities of CO, water vapor, and oxides of nitrogen. Oxygen depletion and CO are serious health hazards that can be life-threatening. Newer models have oxygen-depletion sensors that shut the unit off when the room becomes depleted of oxygen. However, the safe use of unvented gas room heaters requires one or more wide-open windows, which can interfere with the room's heating and comfort level.

### Gas Fireplaces

Gas burning fireplaces and fireplace inserts are very popular. They are valued for their visual appeal, but their annual fuel utilization efficiencies are only 40% to 60%.

Fireplace inserts, consisting of a ceramic log and gas burner inserted into a standard fireplace, are both dangerous and inefficient. The fireplace's chimney draft is unpredictable, because the chimney is a custom-built assembly. A vacuum in the home — caused by exhaust fans or other gas appliances — can easily backdraft the fireplace, polluting the home.

### Wood Stoves

Wood stoves burn wood more efficiently than fireplaces, by moving the fire into the center of the room and surrounding the firebox with room air. Air traveling through the combustion chamber is roughly controlled by a manual damper.

The western states and the Environmental Protection Agency established air pollution limits and boosted efficiency of manufactured wood stoves.

### Wood Stove Installation

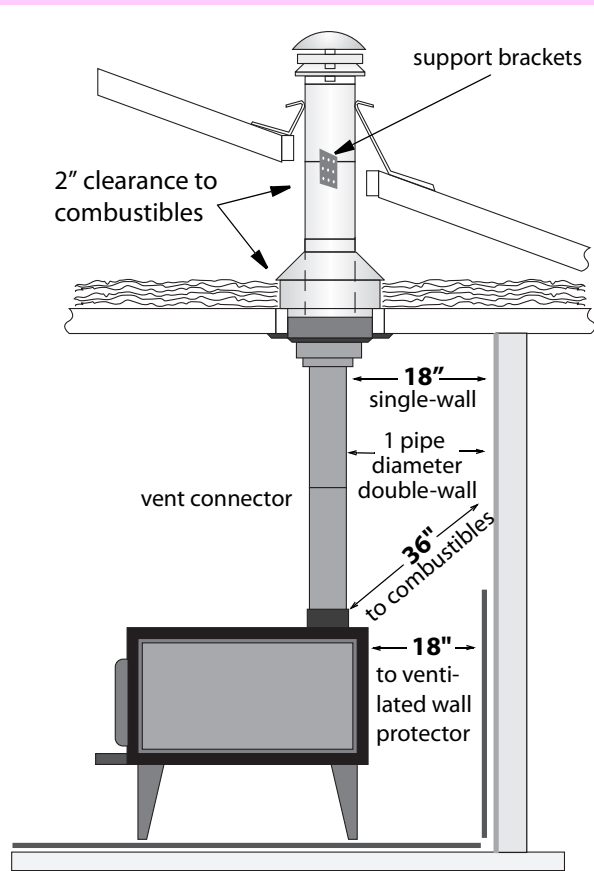

Wood-stove venting and clearances are vitally important to wood-burning safety. Read and follow the manufacturer's instructions for the stove and its venting components.

New wood stoves are tested for efficiency by the EPA. The efficiency of new wood stoves is between 63% and 78%.

Many new stoves use catalytic converters — a honeycombed tube surfaced with a platinum catalyst that burns most of the unburned hydrocarbons from the fire. Non-catalytic, high-efficiency wood stoves use other methods to improve combustion including these.

- ◆ Heated combustion air.
- ◆ Insulated combustion chamber.
- ◆ Secondary combustion air above the flame.

- ◆ Secondary heat exchanger for combustion gases.

The habits of wood-burning users can greatly affect the emissions and efficiency of wood burning. Hot fires pollute less and are more efficient than smoldering fires. Feeding the stove more often helps efficiency and reduces emissions, too. It's important to get the right size wood stove. Larger stoves encourage wood burners to smolder their fires to control heat. Smoldering maximizes emissions and minimizes fuel-burning efficiency.

Wood stoves are a potent fire hazard, if installed improperly. The following safety precautions are recommended by most local fire codes:

- ◆ Use triple-wall pipe or insulated double-wall chimney and maintain 2 inches clearance to combustibles.
- ◆ Keep single-wall metal vent connectors 18 inches away from combustible walls.
- ◆ Keep double-wall metal vent connectors one pipe diameter away from combustible walls.
- ◆ Single-wall stoves must be 36 inches away from combustible walls.
- ◆ Stoves installed closer than 36 inches must be double wall, or walls must be protected by ventilated wall protectors.
- ◆ Stove clearances of less than 36 inches must be specified by the manufacturer and printed on a metal tag attached to the stoves.
- ◆ Bring combustion air from the outdoors to reduce negative pressure around stoves.

### Pellet Stoves

Pellet stoves burn pelletized wood waste at higher efficiency than wood stoves burn wood. The best pellet stoves have over 80% SSE. Pellet stoves have draft inducers that control draft and excess air more precisely than wood stoves' atmospheric draft. Pellets are more uniform and drier than average wood, giving these stoves an added efficiency advantage. However, pellet stoves and their fuel are more expensive than wood stoves.