

A building's heating system provides heat at roughly the same rate as heat is being lost at the design temperatures if it is correctly sized. *Output* is the heater's heat-production rate. The *heating load* is the building's heat loss rate. A heater's output should be larger than the building's heating load, except in the very severest weather conditions, so the heater cycles on and off to satisfy the load for most of the heating season.

The word *heater*, as used here, means a furnace, boiler, or space heater, and *heating system* means the heater and its distribution system. A *circulator* is a blower or pump for moving the heating fluid — air, water, or steam.

There are two types of heaters: room heaters and central heaters. Room heaters deliver all their heat into one area — generally a single room. Central heaters convert fossil fuel or electricity to heat in a central location and employ ducts or pipes to distribute the heat.

### Typical Annual Heating Energy Use

Region & Fuel	Single Family	Multi-family	Mobile Home
<b>Northern U.S.</b>			
Electric (kWh)	*9k–14k	4k–9k	6k–8k
Gas (MMBTU)	80–115	60–70	60–70
Oil (MMBTU)	80–115	55–65	55–65
<b>Southern U.S.</b>			
Electric (kWh)	*4k–6k	2k–4k	1K–5k
Gas (MMBTU)	35–80	20–35	25–40
Oil (MMBTU)	45–90	20–60	20–60
* k=1000. From Lawrence Berkeley Laboratory and Energy Information Administration. (1997)			

Combustion fuels like gas, oil, and wood convert their potential energy to heat at *delivered efficiency* ranging from 35% to 95%. Delivered efficiency is the heating system's useful heat output

divided by the energy input into the heating system. Efficiency is an important concept with combustion heating and there are several types of efficiency discussed in this chapter. The general formula for calculating efficiency is the following.

$$\text{Efficiency} = \frac{\text{Output}}{\text{Input}}$$

Electric resistance heat is considered 100% efficient. Heat pumps are a special type of electric heat that move heat from outdoors to indoors during the heating season and from indoors to outdoors during the cooling season. Heat pumps are generally more than 100% efficient because they can move more than a kilowatt-hour of heat for each kilowatt-hour of electricity they use. However, generating electricity from coal or oil wastes about 70% of the fuel's potential energy. Therefore, electricity is an expensive way to heat.

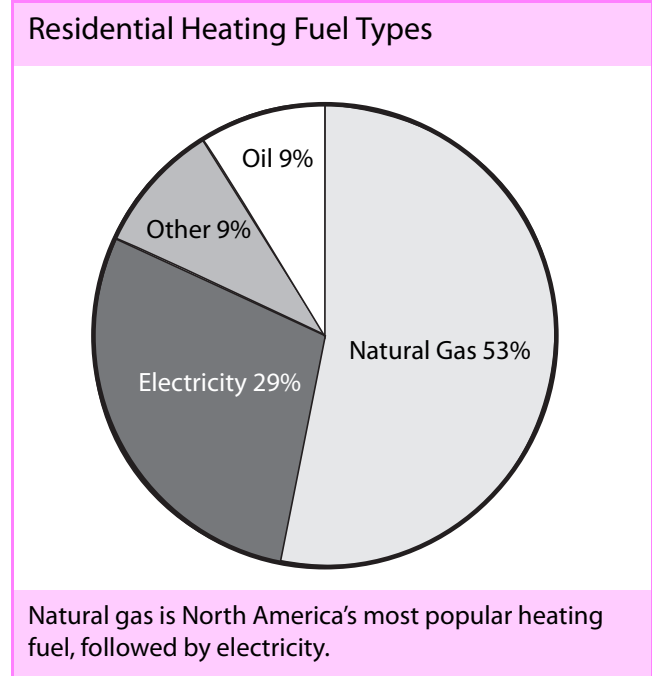



## Combustion Heating Basics

This section introduces the principles and components of gas, propane, and oil heaters. Gas and propane heaters are almost identical and are referred to here as gas heaters. Oil heaters are significantly different from gas and propane heaters.

In gas and oil heaters, burners mix fuel with air for burning in a combustion chamber. The *heat exchanger*, surrounding the combustion chamber, transfers heat from the flame and combustion gases to the heating fluid — air, water, or steam. Combustion gases leave the combustion chamber through the heat exchanger's flue(s), which connects to a chimney.

A *flue* is a passageway for venting combustion gases: a flue may be a space between the heat exchanger's sections or a tube within the heat exchanger. Chimneys are made of metal, masonry, or other noncombustible material. The chimney's inner passageway is often also called a flue.

The efficiency of a combustion heater depends on losses to incomplete combustion, chimney losses, heat losses at the beginning and end of the burner cycle (called off-cycle losses), and losses from the pipes and ducts (called distribution losses). Room heaters have no distribution losses, so they are more efficient than central-heating units.

### The Combustion Process

Combustion fuels are hydrocarbons — molecules composed of hydrogen and carbon. Combustion is rapid oxidation; oxygen combines with the carbon and hydrogen. Carbon dioxide (CO<sub>2</sub>) and water vapor are the main products of this heat-liberating chemical reaction. The flame's heat radiates to surrounding metal and rides on the combustion gases convecting against the heat exchanger's metal surfaces. Some of the flame's heat escapes up the chimney.

### Combustion: The Chemical Reaction

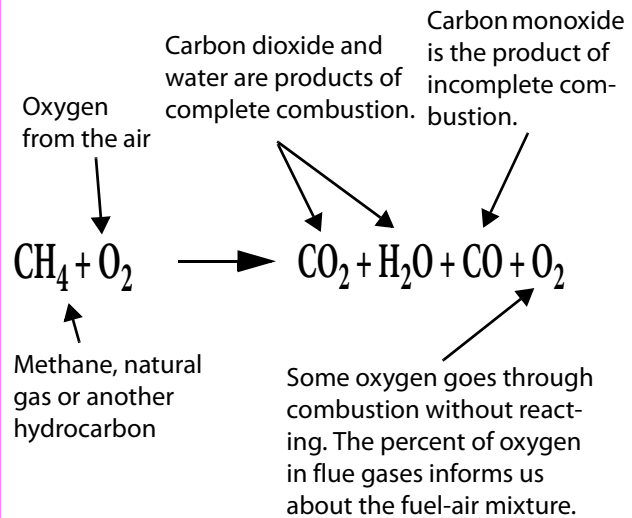

Combustion is a heat-yielding chemical reaction starting with a hydrocarbon and oxygen and producing CO<sub>2</sub> and water as its ideal products.

Air is about 21% oxygen. The other 79% of air is nitrogen, most of which travels through the combustion process unreacted. The combustion gases in the chimney contain unreacted oxygen in addition to the unreacted nitrogen. These unreacted gases absorb heat from combustion and carry the heat up the chimney. Unreacted oxygen, measured in the combustion gases, is a sign of *excess air*, which is inversely proportional to efficiency. See “Combustion Heating” on page 41 for more on principles of combustion.

**Open versus sealed combustion** — The terms open-combustion and sealed-combustion describe whether or not the combustion chamber, heat exchanger, flues, and chimney are open to the surrounding air.

The majority of combustion heaters in homes are open combustion. These heaters draw combustion air from the surrounding room. Older open-combustion heaters also draw indoor air into their chimneys through a dilution device — either

a *draft diverter* (gas) or *barometric draft control* (oil). The air that these devices allow into the chimney is called *dilution air*.

### Open-Combustion, Atmospheric-Draft Heater

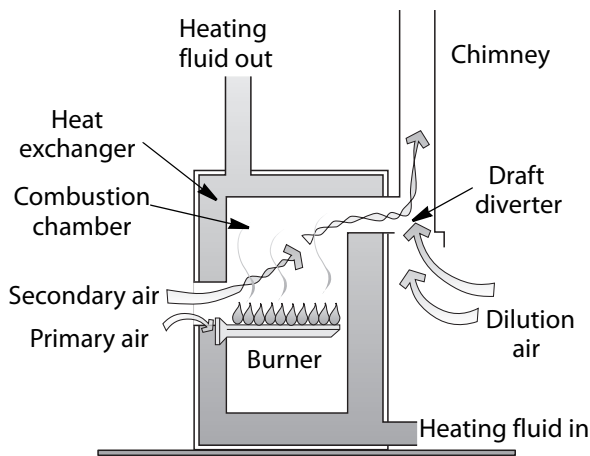

Atmospheric-draft heaters use only the buoyancy of the combustion gases and the flame's heat to exhaust combustion by-products into the chimney and pull combustion air into the burner.

A draft diverter is an opening between the heat exchanger's flues and the chimney. The draft diverter is designed to moderate excessive updrafts and divert downdrafts that might interfere with the burner or extinguish the pilot. A barometric draft control performs the same function except that it regulates dilution air to maintain a consistent chimney draft.

Sealed-combustion heaters are safer and often more efficient than open-combustion heaters. Sealed-combustion heaters have no openings from the home into their heat exchangers or chimneys. Instead, a sealed tube, sometimes combined with the chimney, brings combustion air in from the outdoors.

## Burners

The burner's job is to mix the fuel and air and to burn this mixture. The three common burner types are atmospheric burners, inshot burners,

and power burners. Atmospheric burners are the most common type of gas burner. Gas pressure propels gas through a gas orifice into a venturi tube where the gas mixes with *primary air* admitted by an air shutter. A pilot light, hot-surface igniter, or sparking electrode ignites the mixture. *Secondary air* in the combustion chamber around the flame provides oxygen for the fuel's nearly complete combustion.

### Atmospheric Versus Fan-Assisted Draft

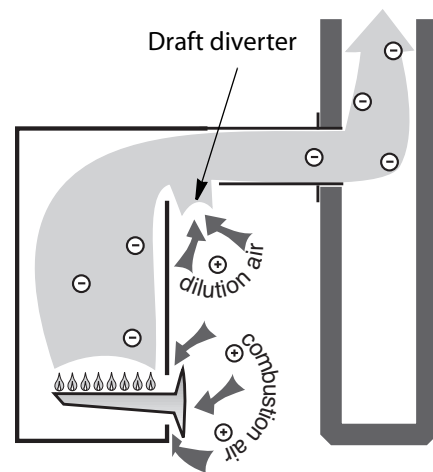

An atmospheric open-combustion heater uses only the buoyancy of the combustion gases to exhaust these gases and to pull combustion air in.

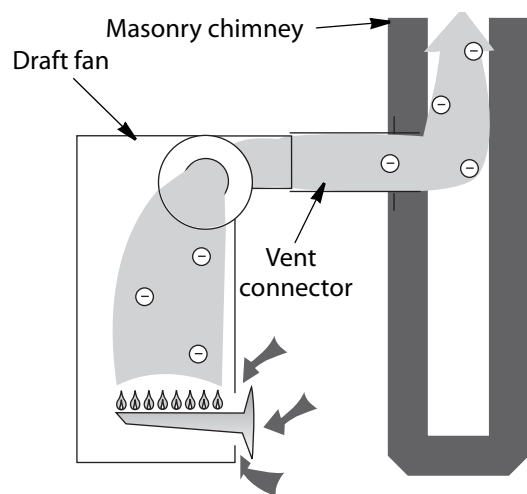

The fan-assisted appliance creates over-fire draft with a draft fan. Chimney draft is atmospheric.

## Power Burner

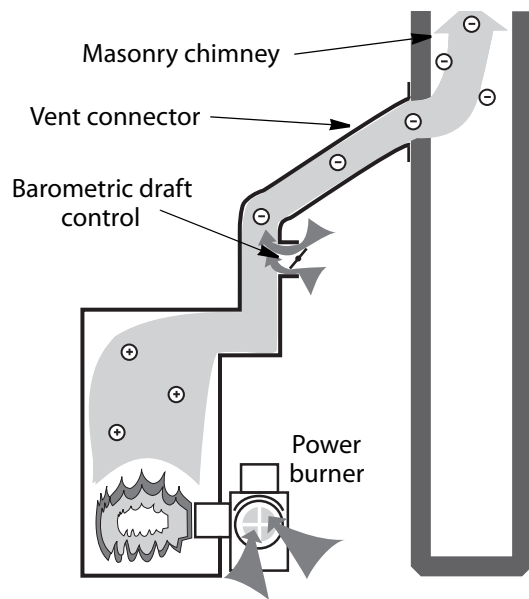

Power burners use a fan to mix combustion air and fuel thoroughly. Combustion by-products are removed by the negative draft of a masonry chimney and vent connector.

Many modern furnaces employ an improved burner type called the *inshot burner*. Inshot burners fire into a tube or stamped heat exchanger that is depressurized by a draft-inducing fan. Their flame takes the shape of the heat exchanger. In this type of appliance, the draft-inducing fan pulls the combustion air in and the combustion gases out. This small fan, however, has little or no pressure effect on the atmospheric chimney where it deposits the combustion gases.

*Power burners* use a blower to pressurize the combustion chamber and move combustion products into the venting system. Electrodes ignite the fuel-air mixture. Shutters on the power burner's blower adjust the fuel-air mixture. The power burner usually deposits its combustion gases into an atmospheric chimney and, like the draft-inducing fan, has little effect on the chimney draft.

## Atmospheric Gas Burner

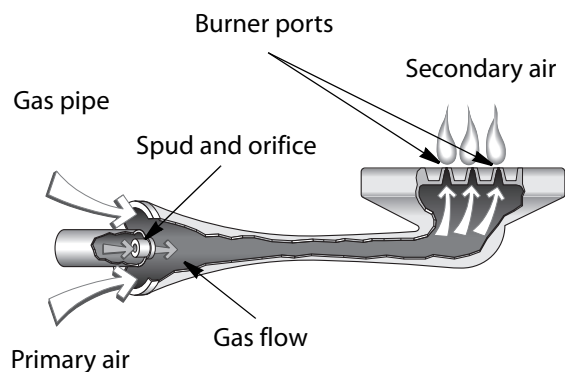

The most common type of burner is the atmospheric-gas burner for burning natural gas or propane.

The most common type of power burner is the oil-atomizing gun burner. An electric motor on the gun burner runs the blower and an oil pump, delivering the oil at a high pressure. The burner's nozzle sprays the high-pressure oil into the combustion chamber where sparking electrodes ignite the atomized oil.

Power gas burners combine a gas orifice, blower, and electrodes for ignition. Power gas burners are found most commonly in multifamily boilers. Power gas burners occasionally replace inefficient atmospheric burners in older single-family furnaces and boilers.

**Draft**

Draft is the force that brings combustion air into the combustion chamber and propels the combustion gases out through the venting system. Draft can be separated into two components: *chimney draft* and *over-fire draft*.

Buoyancy of combustion gases results from the difference in density between these gases and cooler air outside the heater and its chimney. The flue-gas temperature, along with the chimney's height and cross-sectional area determine the strength of chimney draft. Heaters, which depend exclusively on buoyancy for both over-fire and chimney draft, are called *atmospheric heaters*.

### Fan-Assisted Positive Draft

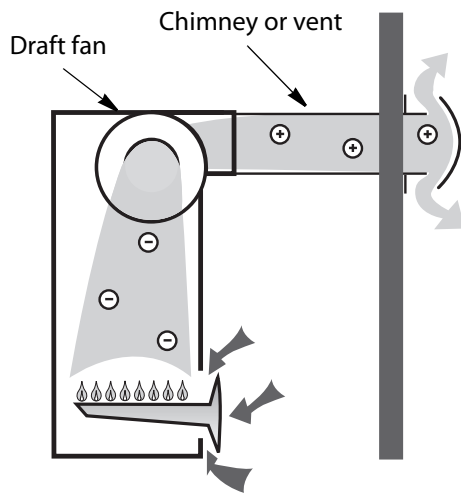

Fan-assisted positive draft is a less common venting option for modern boilers and furnaces. The chimney or vent must be airtight.

Many modern furnaces, boilers, and space heaters have *fan-assisted draft*. These fan-assisted-draft heaters have no dilution device. Their draft fan regulates the over-fire draft and creates a steady flow of combustion air and combustion gases. The draft-assisting fan is located at the inlet (*power burner*) or outlet (*draft inducer*) of the heat exchanger. Either way, the appliance usually vents into an atmospheric chimney.

The elimination of the draft diverter and adoption of fan-assisted over-fire draft is largely responsible for an increase in annual fuel utilization efficiency (AFUE) from 65% in atmospheric-draft furnaces to AFUEs above 80% in similar fan-assisted furnaces. Most fan-assisted heaters are vented into vertical chimneys and their draft fans have little or no effect on the atmospheric chimney draft.

When a fan-assisted 80+ AFUE furnace or boiler is vented horizontally, the draft in the stainless-steel vent is positive. The positive-draft vent must be substantially airtight. Sealed-combustion condensing furnaces and boilers vent through plastic pipe because the flue gases are cool and wet. Sealed-combustion condensing furnaces and

boilers require strong draft fans to overcome resistance from both their venting and combustion-air piping.

Power burners use a fan for mixing combustion air with the fuel and injecting the mixture into the combustion chamber. Power burners create a positive over-fire draft, but heaters with power burners (mostly boilers) usually vent into a standard atmospheric chimney.

### Measuring Chimney Draft

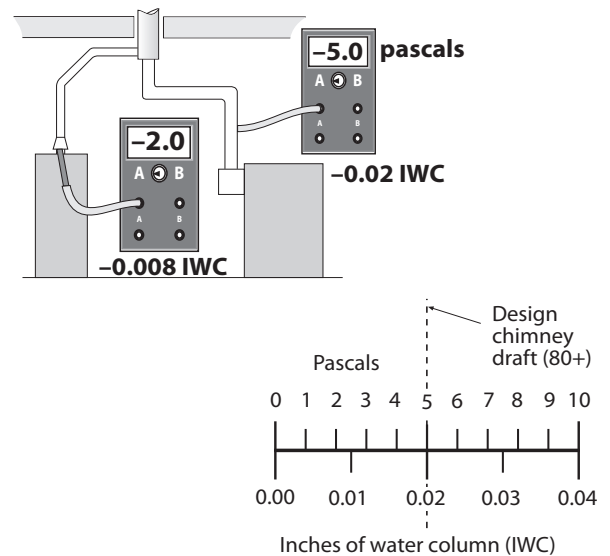

Measuring chimney draft gives important information about the combustion process.

### Chimneys, Liners, and Vents

Chimneys vent combustion gases outdoors vertically. Horizontal vents are becoming more common, replacing chimneys in high-efficiency furnaces, boilers, and space heaters. This section discusses chimneys and horizontal vents.

A chimney develops draft because the gases inside the chimney are lighter than air outside the chimney. A heater at the chimney's bottom burns fuel, which creates the column of lighter-than-air gases. The taller the chimney and the hotter its gases (compared with the air outside) the greater the chimney draft.

## AGA Venting Categories

	Negative-pressure Venting	Positive-pressure
Non-condensing	<p>I</p> <p>Combustion Efficiency <b>83% or less</b></p> <p>Use standard venting: masonry or Type B vent</p>	<p>III</p> <p>Combustion Efficiency <b>83% or less</b></p> <p>Use only pressurizable vent as specified by manufacturer</p>
Condensing	<p>II</p> <p>Combustion Efficiency <b>over 83%</b></p> <p>Use only special condensing-service vent as specified by manufacturer</p>	<p>IV</p> <p>Combustion Efficiency <b>over 83%</b></p> <p>Use only pressurizable condensing-service vent as specified by manufacturer</p>
American Gas Association Vent Categories		

The American Gas Association recognizes four categories of vents for gas appliances. This classification depends whether the vent is positively or negatively pressurized and whether condensation occurs in the vent or not.

Chimneys are either masonry or factory-built metal. Masonry chimneys should be lined with fire clay although many older masonry chimneys are unlined. Clay tile is the most common liner for a masonry chimney. Masons install clay tile liners during construction with round or square clay pipe. The masons provide a space between the liner and the exterior brick to allow the chimney and the liner to expand and contract at different rates.

Factory-built chimneys, employing two or more concentric metal pipes, are very common for residential chimneys. The air space(s) in the concentric pipe keep combustion gases warm and avoid condensation in the chimney. Double-wall, Type-B vent is widely used as gas-appliance chimney. B-vent consists of an aluminum inner pipe and a galvanized-steel outer pipe. B-vent is also the preferred vent connector for 80+ gas furnaces, as well as the preferred retrofit chimney liner whenever there is space inside a masonry chimney to install B-vent.

## Chimneys and Chimney Liners

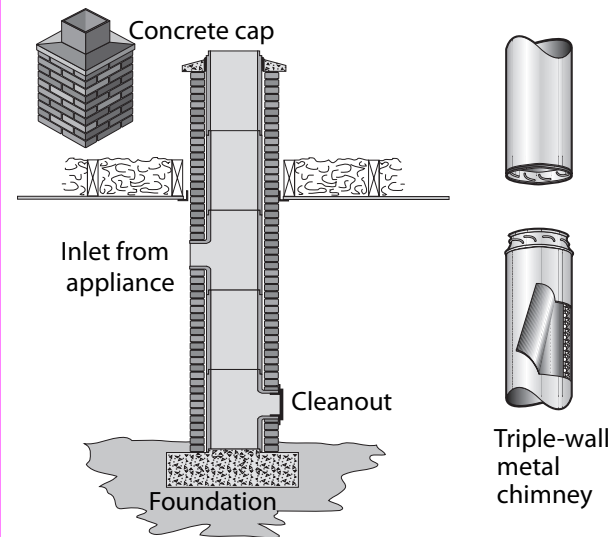

Masonry chimneys should be lined with a fireclay liner and have their own foundations.

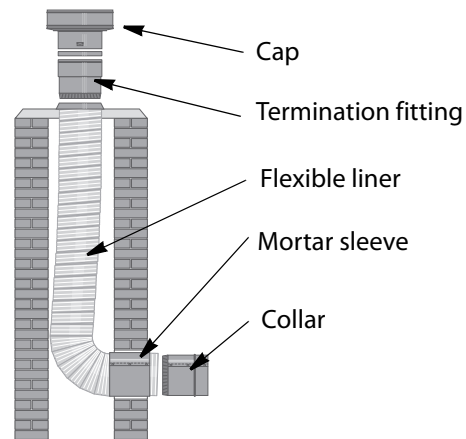

Masonry chimneys without liners or with deteriorated liners should be re-lined with a rigid or flexible chimney liner.

Type-L vent is a vent connector for oil and solid-fuel appliances. L-vent consists of a stainless-steel inner pipe and a galvanized-steel outer pipe.

Insulated double-wall chimneys or triple-wall chimneys — called all-fuel chimneys — serve as vertical chimneys for oil and solid-fuel appliances. These chimneys may penetrate combustible building components like floors, ceilings, and roofs with only two inches of clearance.

### Power Venter

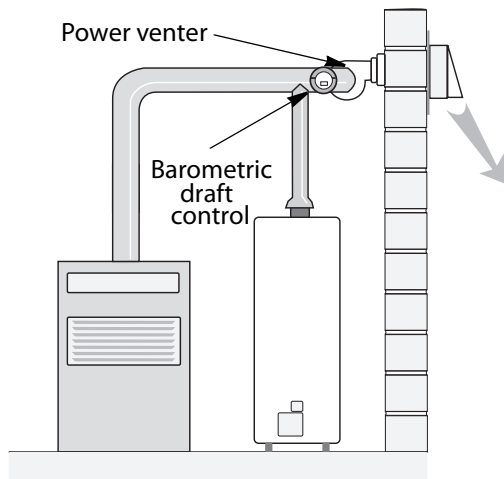

Power venters are fans located at the vent's termination. Power venters are sometimes retrofit onto atmospheric appliances to facilitate horizontal venting when a chimney is failing or absent.

All-fuel chimneys contain manufactured components from the vent connector to the termination fitting on the roof. Parts include: metal pipe, weight-supporting hardware, insulation shields, roof jacks, and chimney caps. One manufacturer's chimney may be incompatible with another's connecting fittings.

See "Wood Stove Installation" on page 179.

Some space heaters, furnaces, and boilers use factory-built metal chimneys with single stainless steel liners that vent horizontally under positive pressure. Condensing furnaces usually employ horizontal or vertical plastic-pipe chimneys. Stainless-steel and plastic vents powered by fans should become standard for gas and oil appliances in coming years to replace atmospheric chimneys, which aren't very reliable venting systems for today's tighter homes.

### Sealed-Combustion Plastic Venting

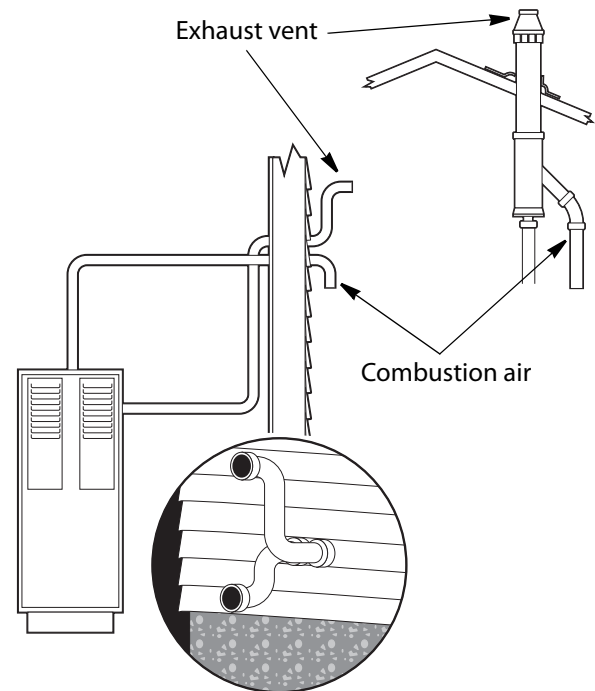

Plastic pressurized condensing vents (Category IV) can run either horizontally or vertically from the condensing appliance.

The need for chimney liners is often ignored during heating-system replacement. Install a new chimney liner when a replacement heater has a higher firing rate than the old one. For example: when a horizontally vented furnace replaces the chimney-vented one, the water heater now vents alone into the chimney designed for both appliances.

The water heater's oversized chimney now needs a liner. Un-lined chimneys and those deteriorating from acidic combustion gases are retrofitted with stainless-steel, aluminum, or masonry liners. Flexible stainless-steel and aluminum liners are popular because they are easy to install. Stainless steel is more durable and thus preferable to aluminum. The best metal liners are smooth stainless-steel piping. Masonry liners are also an option. Masons pour the liners in place using a variety of proprietary processes.

## Losses from Combustion Heating Systems and Resulting Efficiencies

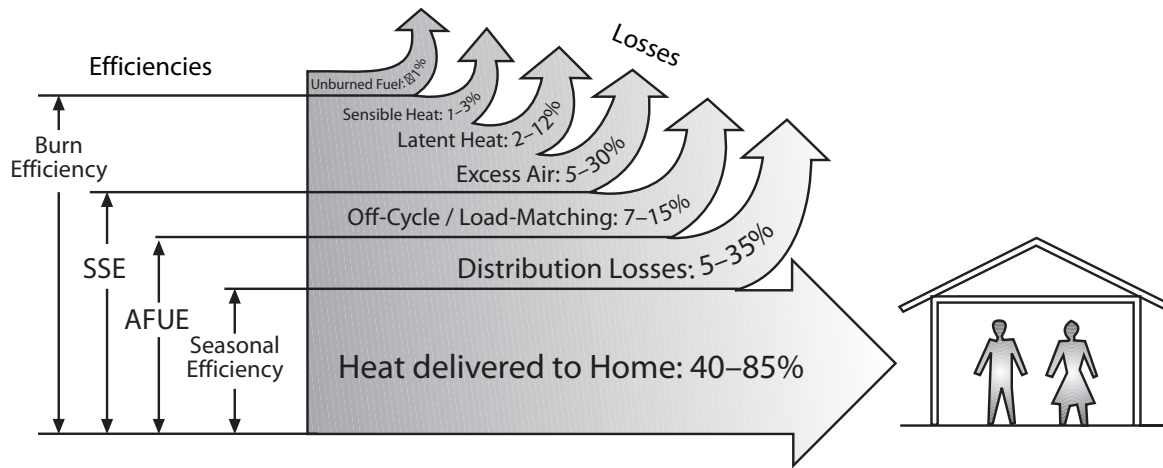

Much of the heat contained in the fuel never reaches the living space as useful heat. Fuel-burning efficiency counts losses from incomplete combustion. Steady-state efficiency (SSE) counts chimney losses. Annual fuel utilization efficiency (AFUE) counts cycling and jacket losses. Seasonal efficiency counts distribution losses in addition to the others and would be the lowest efficiency (40% to 85%).

### Types of Efficiency

Efficiency is an important indicator of heating performance. The fuel buyer pays for the portion of heat wasted in addition to the portion used.

Heating specialists express heating efficiency in four different ways.

1. Fuel burning efficiency.
2. Steady-state efficiency (also called combustion efficiency).
3. Annual fuel utilization efficiency (AFUE).
4. Delivered heating efficiency (also called seasonal efficiency).

The four types of efficiencies to be discussed account for the succession of losses as heat travels from the burner through the heat exchanger and distribution system.

Fuel-burning efficiency is the percentage of the fuel's potential energy converted to heat at the flame. Most modern oil-fired heaters and gas heaters have a fuel-burning efficiency of over 99%.

Steady-state efficiency (SSE) is the percentage of heat captured by heating fluids: air, water, or steam. SSE accounts for fuel-burning losses and chimney losses. The SSE can be measured with CO<sub>2</sub>-sensing or oxygen-sensing devices and thermometers.

All combustion furnaces, boilers, and room heaters must leave the factory with an energy guide label listing the AFUE. AFUE is the laboratory-tested efficiency that accounts for: fuel-burning losses, chimney losses, cycling losses, and heat loss through a central heater's cabinet. AFUE does not account for distribution losses through ducts or pipes. The AFUE is the percentage of the potential energy in the fuel that flows into the heating distribution ducts or pipes on a seasonal basis.

Delivered heating efficiency is the most difficult type of heating efficiency to measure because delivered efficiency includes distribution losses. Delivered efficiency is the percentage of the fuel's potential energy that actually heats the living



space. With all the ways to lose heat between the flame and the living space, the delivered heating efficiency can be as low as 35%.

### Combustion Heating System Energy Loss

The combustion heater liberates chemical energy as heat at its flame. Some of that chemical energy is wasted by incomplete burning. Some of the flame's heat escapes up the chimney. Much of the residual heat remaining after the flame extinguishes is wasted, depending on the efficiency of heat transfer and circulator operation. The distribution system's pipes or ducts lose some of the heat. A central heater's pump or blower uses electrical energy, much of which never contributes heat to conditioned space and so can be considered waste. The following is a more detailed accounting of these losses.

**Dilution air** — Dilution air is the heated building air used by conventional furnaces and boilers to moderate chimney draft and reduce excess combustion air. There are two common dilution devices that admit dilution air to the chimney: the draft diverter and the barometric draft control. The draft diverter is simply a large opening in the appliance's flue, which allows air into and out of the chimney. The barometric draft control is a damper that allows air in and out of a chimney depending on the pressure in the chimney. The barometric control is widely used with gas and oil power burners and regulates chimney draft, creating more stable and efficient combustion than a draft diverter.

Unfortunately, at least 80 percent of existing gas appliances still have draft diverters rather than barometric draft controls or induced-draft (ID) fans, which regulate combustion gases in high-efficiency furnaces. Most new boilers and water heaters still use draft diverters.

If dilution air is heated building air, the dilution air represents a significant heat loss. Gas furnaces and boilers without draft diverters are above 78%

AFUE, while older models with draft diverters are in the 60% to 70% AFUE range. Therefore, eliminating dilution air is one of the most important advances in heating evolution.

**Combustion air** — Excess combustion air — more than required to oxidize all the carbon and hydrogen molecules in the fuel — ensures complete combustion and avoids carbon monoxide (CO) production. Excess air also wastes energy. Combustion air provides oxygen to the burning fuel as both primary air or secondary air. Secondary air is the main source of excess air and depends on the air-intake area in front of the burner and the over-fire draft.

Excess combustion air absorbs heat and carries it up the chimney, so the best systems minimize excess air. If it were possible to allow only the exact amount of air absolutely necessary for combustion into the firebox, there would be 0% excess air. Efficient combustion heaters allow 20% excess air, but 100% excess air is not unusual in heaters equipped with draft diverters and having no draft fan. The greater the excess air percentage, the lower the efficiency, and even modern heaters may have high excess air. One failing of modern American heaters is that manufacturers provide no way to adjust the flow of combustion air.

See "Combustion Air Alternatives for Confined Spaces" on page 153.

**Cycling losses** — The heat required to warm up the furnace or boiler is partially wasted when it cools down. If the heating fluid continues to circulate through the heat exchanger after the burner shuts off, this waste is minimized because the stored heat continues to flow into the building. The amount of cycling losses depends on the following factors.

- ◆ The number of cycles,
- ◆ Amount of heat required to warm up the heat exchanger, and
- ◆ The efficiency of distribution system operating after the burner extinguishes.



Off-cycle losses can be minimized by vent dampers, draft fans, and smaller heat-exchanger passageways that restrict off-cycle airflow through the heat exchanger and venting system. Room heaters have far less off-cycle losses than central heaters because most of the heat stored in the heat exchanger escapes into the room rather than out the vent.

Furnaces and boilers are designed to achieve their maximum efficiency at maximum output and load. When the heating load is less than the heater's output, then the furnace or boiler cycles on and off. Numerous, shorter cycles waste energy through greater off-cycle losses. However, longer cycles may overheat the building, waste energy, and cause discomfort. This is why selecting a furnace's or boiler's output correctly reduces waste caused by both off-cycle losses and overheating. This principle is more important with boilers than with furnaces because of the boiler's heavier heat exchanger and heating fluid.

**Distribution losses** — Distribution losses typically amount to 5% to 30% of the heat contained in the fuel being burned by a furnace or boiler. Distribution losses are partially reclaimed if the pipes or ducts run through heated spaces. If these distribution losses heat an unconditioned space, heat loss from the conditioned to the unconditioned space is reduced. However, central heating systems are designed to heat rooms through registers, radiators, or baseboard convectors. Usually, distribution losses are at least partially wasted — escaping from unconditioned spaces or overheating conditioned spaces.

Heat escapes the distribution system in two ways.

1. The heating fluid — air, water, or steam — escapes from the ducts or pipes.
2. Convection and radiation carry heat away from pipes and ducts.

Leaks in pipes and ducts are the most severe distribution problems. You can reduce convection and radiation by installing pipe or duct insulation.

If the distribution system is undersized or its circulator is functioning poorly, this reduces heat transfer at the central heater's heat exchanger. More of the flame's heat escapes up the chimney.

## Combustion Safety and Efficiency

Combustion heaters are, statistically, among the most dangerous hazards found in residences. Fire and indoor air pollution are the most common problems.

Home-heating systems are more likely to be dangerous than those of multifamily buildings because of stricter multifamily safety standards and the home heater's closer proximity to residents. Room heaters are particularly dangerous, because of their location within the living space.

Ideally, a heating professional performs maintenance and safety checks annually for all oil-fired equipment. Gas furnaces and boilers burn cleaner and have less moving parts than oil, so they need service less often.

### Combustion-safety Issues

CO is the greatest indoor pollutant threat from combustion heating. This colorless, odorless gas can sicken or kill the building's occupants. Other gases affecting health include nitrous oxide, water vapor, and sulfur dioxide. These gases can escape into the building's living spaces through cracked heat exchangers, backdrafting, and spillage. Combustion air is essential for safe operation of combustion heaters.

**Flame-safeguard controls** — Heaters are a major cause of fires. Combustible materials should be kept at a safe distance from hot components of the heater. Electrical components should be inspected for safety at least biannually. A smoke alarm should be located in or near the heater's space.