

Split-System Air Conditioner

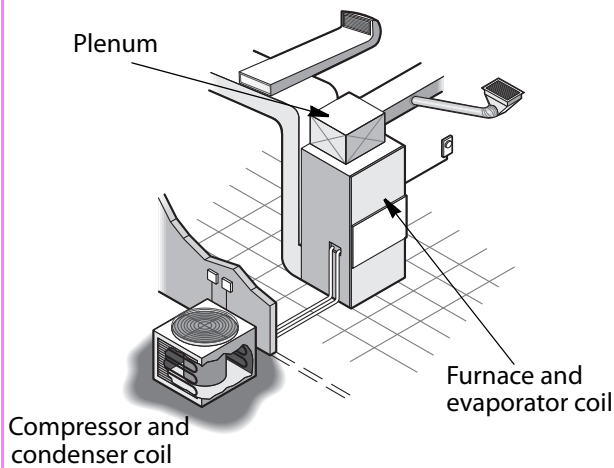

This upflow furnace has the evaporator coil in its plenum (main supply duct). The condenser and compressor are outdoors. Split system air conditioners can be a part of combustion furnaces, electric furnaces, or heat pumps.

Mini-Split Air Conditioning System

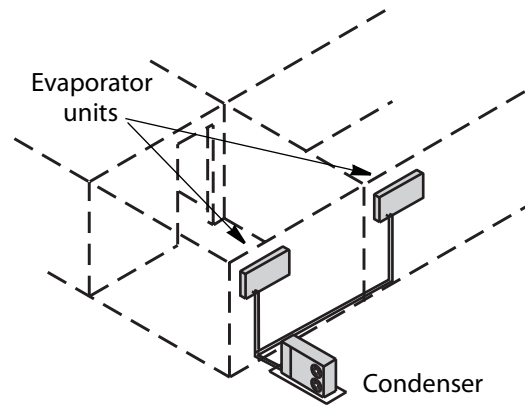

Mini-split systems employ a cooling unit—with an evaporator coil and fan—in each room. The condensing unit serves up to four indoor units.

Room Air Conditioners

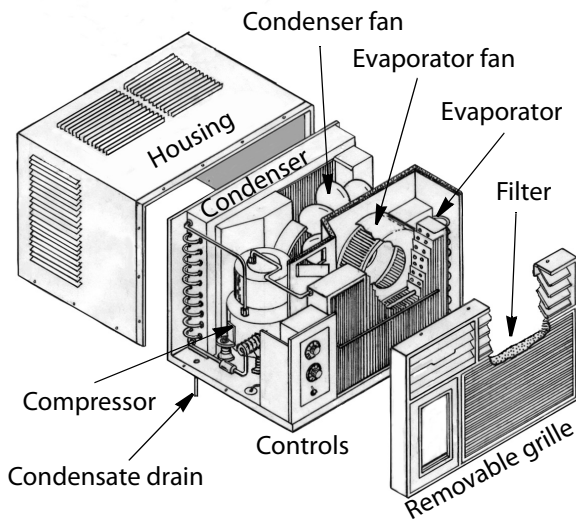

Room air conditioner performance deteriorates as it accumulates dirt. The air conditioner will eventually break down or fail to cool the room unless it is cleaned.

Packaged Air Conditioner

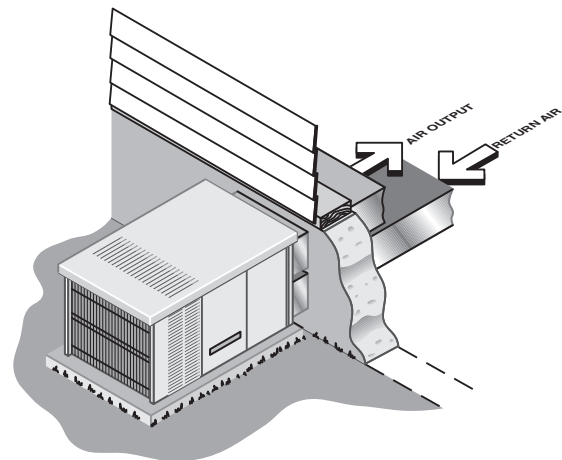

The packaged air conditioner contains an evaporator, condenser, compressor, and all the other parts in a single cabinet located outdoors. Indoor air is circulated through the evaporator and cooled, while the outdoor air absorbs the heat collected indoors.

Power Draw and Hourly Cost for Cooling

Cooling Device	Watts	Cost (¢/Hour)
Central air conditioner	2000–5000	16–40
Room air conditioner	500–3000	4–24
Evaporative Cooler	400–1800	3–15
Whole-House Fan	300–600	2–5
Circulating/Exhaust Fan	25–200	0.2–1.6

The ranges of watts and hourly cost represent the different sizes of the cooling devices. The hourly cost assumes 8¢ per kilowatt-hour.

Types of Air Conditioners

Central air conditioners have supply and return ducts that connect to a central air handler. The condenser unit is outside and releases heat collected from inside the house. Most central air conditioners are *split-systems*—that is, they have the evaporator coil indoors and the condenser coil outdoors. *Packaged air conditioners* have both coils outdoors.

Room air conditioners work well for smaller homes or homes in mild climates, where residents use air conditioning occasionally. Room air conditioners install in a window or a hole in the wall—wall installations being preferable for appearance. Room air conditioners save energy by cooling only the home's occupied areas, rather than the entire house.

Mini-split system air conditioners combine features of room air conditioners and central split-system air conditioners. Mini-splits, as they are called, use an evaporator coil and fan in each room with a single condensing unit outdoors. They have no ducts. This new type of air conditioner is more expensive than standard room air conditioners, and it may even cost more than a conventional central air-conditioning system. Designers and contractors use them when there is

no space to install ducts. Mini-splits can save energy over central air conditioners when used for spot cooling occupied rooms instead of the whole house—a conservation measure not practical with conventional central air conditioners.

Each of these types may be purely an air conditioner or a heat pump. Heat pumps are reversible air conditioners that move heat in or out of the home, depending on the season.

Air-conditioner Efficiency

The energy ratings of air conditioners are based on how many BTUs (heat) per hour the unit can remove for each watt of power it draws.

For central air conditioners, the efficiency rating is called the *Seasonal Energy Efficiency Ratio*, or SEER. For room air conditioners, it is called *Energy Efficiency Ratio*, or EER.

$$\text{SEER or EER} = \frac{\text{BTUs per hour heat removed}}{\text{Watts of electrical power drawn}}$$

Air conditioners with higher EER or SEER generally cost more, but the energy savings will return the higher initial investment several times during the air conditioner's life. The Energy Guide Label, listing EER or SEER, must remain on the air conditioner until it is sold.

The most efficient air conditioners are listed by size and efficiency in the *Consumer Guide to Home Energy Savings*, published by the American Council for an Energy-Efficient Economy. See Bibliography.

Buy the most efficient air conditioner you can afford, especially if you live in a hot climate, or if your air-conditioning costs are high.

Room air conditioner sizes range from 5500 BTUH to 14,000 BTUH. National appliance standards require room air conditioners built after January 1, 1990, to have an EER of 8.5 or greater.

An EER of 10 is considered very energy-efficient. If you live in a mild cooling climate, select a room air conditioner with an EER of at least 9.0. Select one with an EER over 10 if you live in a hot climate.

National appliance minimum standards for central air conditioners require a SEER between 8.9 and 10.0, depending on when the unit was manufactured. There is a wide selection of units available with SEERs up to almost 17. Before 1979, the SEERs of central air conditioners ranged from 4.5 to 8.0. Replacing a 1970's vintage central air conditioner that has a SEER of 6 with a new unit that has a SEER of 12 will cut air-conditioning costs in half.

To determine the approximate SEER of an existing central air conditioner, find the model number and manufacturer from the nameplate on the outdoor unit. Contact a local dealer of that manufacturer's equipment and ask them to look up the efficiency rating for you. If they can't give you the efficiency rating, ask them if they know of a local manufacturer's representative who can estimate the efficiency.

New Energy-efficient Air Conditioners

The efficiency of today's air conditioners is much greater than air conditioners made in the mid-1970s. This improvement in efficiency has resulted from technical advances such as:

- ◆ Variable-speed or two-speed blowers.
- ◆ Copper tubing grooved inside to increase surface area.
- ◆ Aluminum fins spaced closer together and perforated to improve heat transfer to air.
- ◆ Improved electric motor design.
- ◆ Dual-speed compressors.
- ◆ Time-delay relays controlling evaporator fans.

Sizing and Selecting Air Conditioners

Size is a very important consideration to achieve comfort and minimize energy cost when selecting new air-conditioning equipment. Oversized air conditioners cycle more than correctly sized ones. With each cycle, the air conditioner has to heat the condenser, cool the evaporator, and cool the ductwork before beginning to cool the home. This start-up energy is wasted at the end of the cycle, so more cycles waste more energy.

When selecting air conditioners, consider cooling, moisture removal, and energy efficiency. The amount of heat gain during the hottest (and most humid) weather is used to determine the air conditioner's *capacity*. This capacity is measured in BTUs per hour, or "tons" of cooling. Each ton equals 12,000 BTUs per hour (1 ton = 12,000 BTUs/hour).

Reputable contractors size air-conditioning systems accurately, using hand calculations or computer programs. The Air Conditioning Contractors of America publishes a calculation procedure called Manual J, the standard method for sizing central air conditioners. Several air-conditioning manufacturers and others have developed computer programs based on Manual J or on other calculation methods.

"One ton per 400 square feet of floor space" is an archaic rule-of-thumb used to estimate the size of central air conditioners in older, less efficient homes. However, sizing the system smaller to provide one ton per 700 to 1200 square feet of floor space will provide better efficiency and humidity control in energy-efficient homes.

Contractors normally oversize air conditioners by 30% to 100% to ensure they are big enough to cool the home. However, properly sized air-conditioning systems are more efficient and more effective at removing moisture than oversized systems.

Variation in Cooling Load

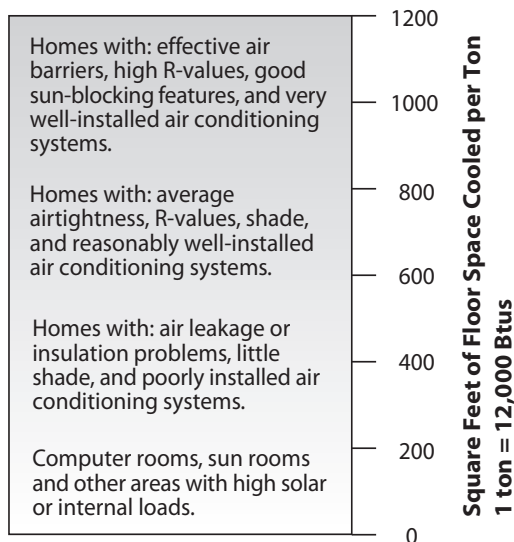

The number of square feet of floor space that can be cooled by a ton of air conditioning depends on climate, shade, insulation levels, and air leakage.

Moisture removal capacity of the system—measured by *sensible heat factor (SHF)*—is an important consideration for selecting a central air-conditioning system. The SHF rates the air conditioner on its ability to remove moisture. The SHF is a decimal number between 0.5 and 1.0. The lower the SHF, the more moisture the unit will remove from the air. The SHF depends on the size and construction of the evaporator coil, and on the fan speed.

Cooling comfort is provided by reducing air temperature and removing humidity. The air conditioner must run for long enough at a cold enough evaporator-coil temperature to remove necessary moisture. The moisture condenses on the cold coil and is piped away through a drain. Oversized air conditioners cycle frequently, remove less moisture, and waste energy. Long cycles are good for energy efficiency and moisture control. However, an air conditioner that runs all the time isn't necessarily sized correctly. It could be oversized, and straining to overcome maintenance, repair, or adjustment problems. Or, it could be undersized.

Variation in Fan Speed

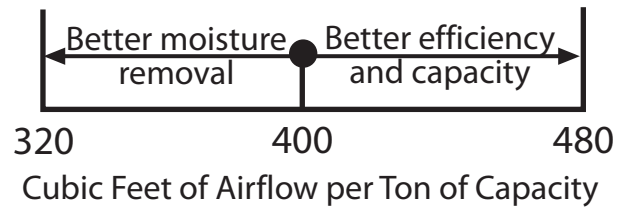

Manufacturers allow for a variation of 20% from the rule of 400 CFM per ton.

Homeowners in dry and moderate climates should select a high SHF because they need less moisture removal, and air conditioners with high SHF are more efficient. However, air-conditioning systems for humid climates normally require an SHF between 0.67 and 0.77 to reduce humidity. A relative humidity of less than 40% discourages biological pests linked to respiratory problems.

Proper sizing and equipment selection are especially important with new higher efficiency air conditioners. These new energy-efficient units must have a low enough SHF to provide adequate moisture removal for a particular climate. An oversized new air conditioner or one with mismatched parts—evaporator, condenser unit, and blower—won't reach its potential high efficiency, nor will it remove enough moisture to provide adequate comfort.

Air Conditioner Installation

Many air conditioners fail to achieve their rated efficiency because of faulty installation. The most common problems are low airflow, incorrect refrigerant charge, and duct air leakage. The roots of these problems lie in inadequate planning, installation space, and technician training compounded by the selection of low bid contractors.

Air-conditioning systems in new homes should be planned and designed into the home's blueprints and specifications. A heating, ventilation, and air conditioning (HVAC) contractor should be consulted about the physical sizes and clearances of equipment and ducts, so that adequate space is provided for them. Ducts merit special consideration because they are large and need to connect to all main rooms. The HVAC contractor should work with carpenters, plumbers and electricians to ensure that pathways for ducts are not obstructed.

Replacing an air-conditioning system also requires planning. Undersized ducts are so common that provision should be made for correcting inadequate airflow. Increasing duct sizes, reducing the air conditioner's capacity, or replacing the ducts are possible options.

All new systems should be checked for correct charge and airflow. Ducts should be checked for leakage.

Thermostatic Control of Air Conditioners

Turning the thermostat past the desired temperature will not make the air conditioner cool your home any faster, and it will waste energy. Dueling managers—residents who move the thermostat setting back and forth to suit their different comfort demands—also cause air-conditioning systems to operate erratically and inefficiently.

The location of a thermostat can cause problems in controlling cooling systems. Thermostats should be shaded from direct sunlight. A thermostat located on a warm outside wall may cause the air conditioner to operate erratically.

Residents who leave and return at regular times every day can save money and increase the comfort and convenience of both cooling and heating by using automatic setback heating/cooling thermostats.

Improving Forced-Air Circulation

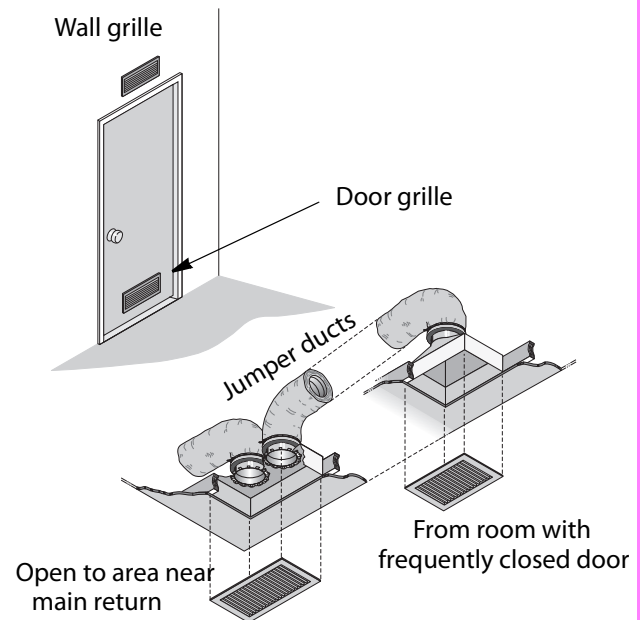

Closed interior doors create a return-air blockage in systems with only one or two returns. Grilles through doors or walls or jumper ducts can reduce house pressures, improving circulation and comfort.

Thermostats often do not provide good comfort control in very humid climates. Manufacturers have developed air-conditioning controls that respond to both temperature and humidity, and have developed variable-speed blowers that are more flexible in providing both cooling and humidity control.

Airflow and Performance in Central Air Conditioners

The cooling capacity and the efficiency of the system depend on adequate airflow. There should be about 400 cubic feet per minute (CFM) airflow in the system for each ton of air-conditioning capacity. A designer may specify more airflow for drier climates to increase efficiency or less airflow for more humid climates to increase moisture

removal. Central air conditioners are designed to cool the whole house; closing registers in unused rooms will not usually save energy.

Service technicians measure the airflow in the air-conditioning system in a variety of ways. The duct blower is often a more accurate tool for measuring system airflow. Using a flow plate, especially designed for measuring system airflow may also be fairly accurate. Flow hoods can also give a reasonably accurate value for system airflow if used according to the manufacturer's instructions and calibrated with a duct blower. Measuring pressure drop or temperature difference across the coil or across the air handler can indicate whether airflow is adequate. Duct sealing should precede airflow measurements to increase their accuracy.

When the air-conditioning system is operating, the temperature drop between supply and return air should be 15° to 21°F dry bulb or 8° to 12°F wet bulb temperature. *Wet-bulb temperature* accounts for the heat carried by the air's humidity. A reading outside these ranges could indicate a problem with airflow or refrigerant charge.

These temperature change measurements can also estimate cooling rate and coefficient of performance (COP). Technicians can calculate COP by determining the airstream's change in enthalpy (energy content) across the indoor coil by measuring temperature drop. The enthalpy change is divided by the system's electrical input to obtain COP. An air conditioner or air-source heat pump should have a COP of between 2 and 3. A measured COP of between 1 and 2 indicates poor performance, likely due to airflow or refrigerant problems.

Improving airflow — Technicians increase the airflow by cleaning the evaporator coil, increasing fan speed, or enlarging the ducts—especially return ducts. Enlarging ducts may seem drastic, but in some cases might be the only remedy for poor cooling efficiency and high cooling costs.

Measuring Airflow

Duct Blower Method

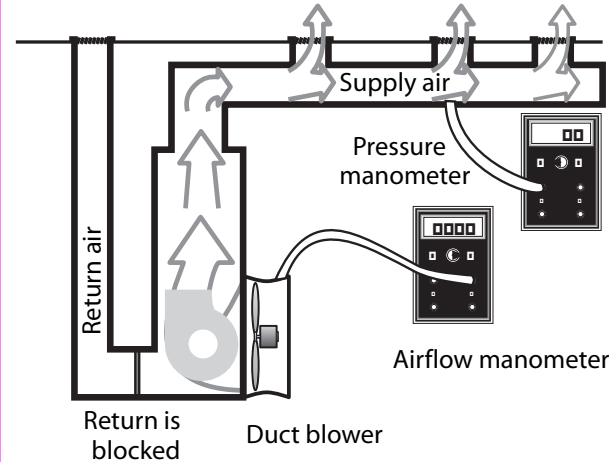

Flow Plate Method

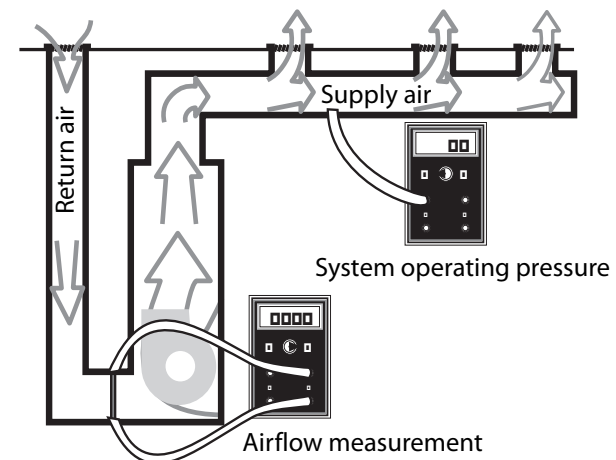

Flow Hood Method

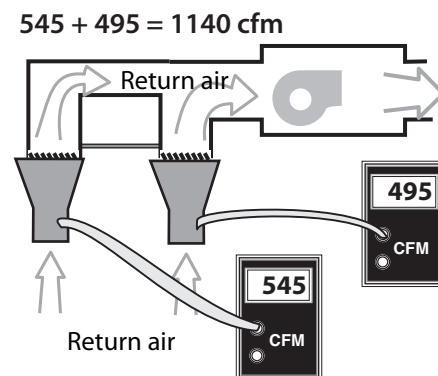

Technicians should measure airflow during a tune-up. These methods are among the most accurate for measuring airflow. Instrument calibration and the system's air leakage can affect testing accuracy.

Maintaining Evaporator Coils

Gain access from side or bottom to clean coils.

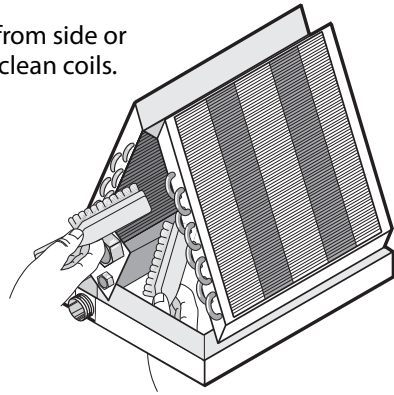

Access the a-coil from the side or underneath in up-flow systems. Clean the fins by brushing, then spraying with cleanser and rinse water, if necessary.

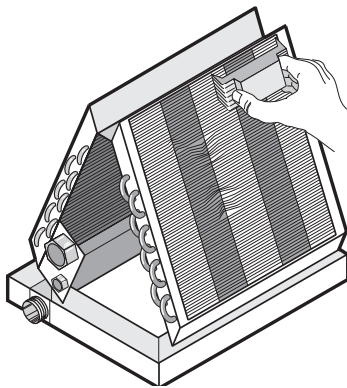

Fin combs are available in various "fins/inch" models.

If the evaporator or condenser fins are bent, they can be combed back into original condition with a fin comb.

Air from every supply register must have an unobstructed airway back to a return register. Blockage of supply or return air ducts and registers can pressurize or depressurize portions of the home, resulting in poor air-conditioning performance and increased air leakage through the building shell. Remedies may include cutting off the bottoms of doors or installing louvered grilles through walls or doors. Installing more return ducts or ducts between rooms are also options for improving air circulation.

Obstructions in the supply air ducts include dents, debris inside the ducts, and bent or dirty registers. Supply registers can have severe blockages if the fins have been flattened by foot traffic or if they are dirty.

Insulated flexduct, as installed in many modern homes, is often kinked or crushed, causing a significant airflow problem. Fiberglass duct board has far less structural strength than galvanized-steel ducts. Crushed or damaged duct board can be an airflow problem. Fiberglass duct liner (installed inside metal ducts) may deteriorate over time from moisture and vibration, partially blocking the duct's airway.

Supply registers closest to the air handler sometimes deliver too much or too little cool air to the rooms. Change the room airflow by moving the balancing dampers at the duct's takeoff, adjustable vanes in registers, or by sealing off portions of the over-supplied registers. It is not usually a good idea to block off registers altogether, because this reduces airflow and cooling efficiency.

Sealing Leaky Ducts

Testing ducts for air leakage, finding duct air leaks, and sealing ducts are discussed in "Duct Air Leakage" on page 89 and "Duct Leakage Comparisons" on page 67.

Refrigerant Charge

Room air conditioners and packaged air conditioners are charged with refrigerant at the factory. Split-system air conditioners and heat pumps are charged in the field and many of these have too much or too little refrigerant. Split systems that have the correct refrigerant charge and airflow usually perform very close to manufacturer's specifications for SEER and COP. Manufacturers say that a technician must measure airflow prior to checking charge because the charge measurements aren't accurate unless airflow is verified at 400 CFM (±80 CFM) per ton of cooling capacity.

For satisfactory performance and efficiency, a residential central system should be within an ounce of the correct charge as specified by the manufacturer. When the charge is correct, the system will have specific refrigerant temperatures listed by the manufacturer. Two commonly listed measurements are *superheat* and *subcooling*, which are the number of degrees the refrigerant is heated or cooled from its saturation temperature. Saturation temperature is the point between liquid and vapor that exists in both the evaporator and the condenser. The vapor needs superheat to dry it in preparation for compression. The liquid from the condenser needs subcooling to insure that it doesn't flash into a gas before it reaches the evaporator.

Superheat, subcooling and other charge tests must typically be done during the cooling season. New air conditioners and heat pumps, installed or serviced during the heating season, are charged by weight. Refrigeration systems should be leak-checked at installation and every service call. Refrigerant must be added and withdrawn carefully and according to standards specified by the Environmental Protection Agency (EPA).

Maintenance and Service

Air-conditioner efficiency is dependent upon routine maintenance. The difference between the energy consumption of a well-maintained air-conditioning system and a severely neglected system ranges from 10% to 30%. The following routine maintenance tasks could be performed by a skilled technician or homeowner:

- ◆ Clean or replace filters regularly (depending on operating time, every 1 to 4 months).
- ◆ Clean supply and return registers and straighten their fins (dirt and damage are visible).
- ◆ Clean the blower's fan blades.
- ◆ Clean evaporator coil and condensate pan every 2 to 4 years.
- ◆ Clean condenser coils each year or two (dirt may or may not be visible).
- ◆ Remove debris from around condenser.
- ◆ Straighten bent fins in evaporator and condenser coils.

Professional Service and Commissioning

Adjustments and repairs to air conditioners are strictly for professionals. Even many professionals don't know how to install and service air-conditioning systems correctly. So there is no guarantee that basic operating requirements—correct sizing, airtight ducts, the correct amount of refrigerant, and adequate airflow—are present in existing air-conditioning systems. When a heating and cooling contractor is hired to measure performance and make necessary changes and repairs, this extensive service call is called *commissioning*.

An expert professional service technician might perform the following procedures to service or commission a central air conditioner:

- ◆ Checks ducts, filters, blower, and indoor coil for dirt and other obstructions.
- ◆ Verifies correct electric control, especially that heating is locked out when the thermostat calls for cooling and vice versa.
- ◆ Diagnoses and seals duct leakage.
- ◆ Verifies adequate airflow by measurement.
- ◆ Verifies correct refrigerant charge by measurement.
- ◆ Inspects electric terminals—cleans and tightens connections and applies non-conductive coating, if necessary.
- ◆ Oils motors and checks belts for tightness and wear.
- ◆ Checks thermostat operation.

Checking Refrigerant Charge

Superheat is the temperature difference between evaporator saturation temperature and the vapor temperature at the compressor's inlet.

Pressure gauges give the technician another way to get saturation temperatures of the evaporator and condenser by consulting pressure-temperature tables.

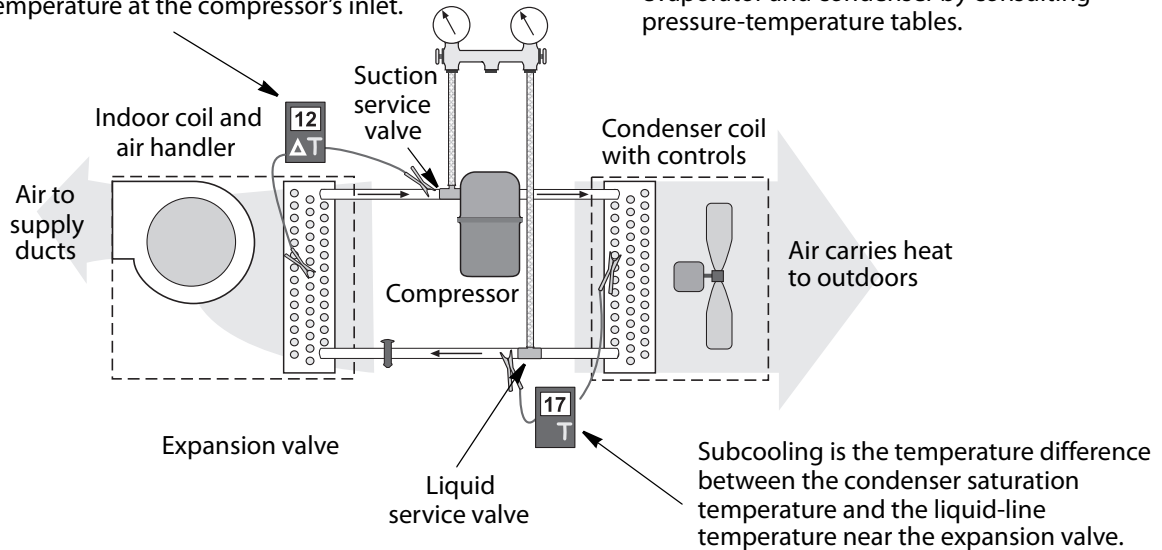

Technicians measure superheat or subcooling temperatures during summer cooling. These measurements indicate whether or not the refrigerant charge is correct.

Pressure and Temperature Differences Across the Indoor Coil

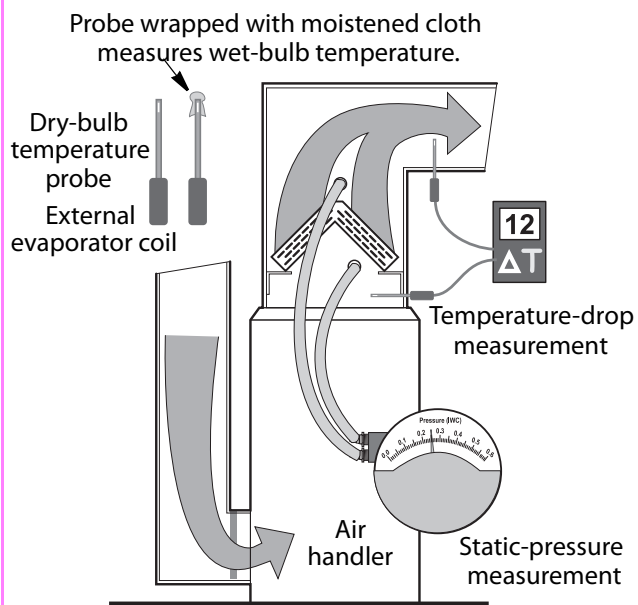

Temperature and pressure differences across the indoor coil give an indication of airflow's adequacy.